

Flexible Jaw Couplings

Martin

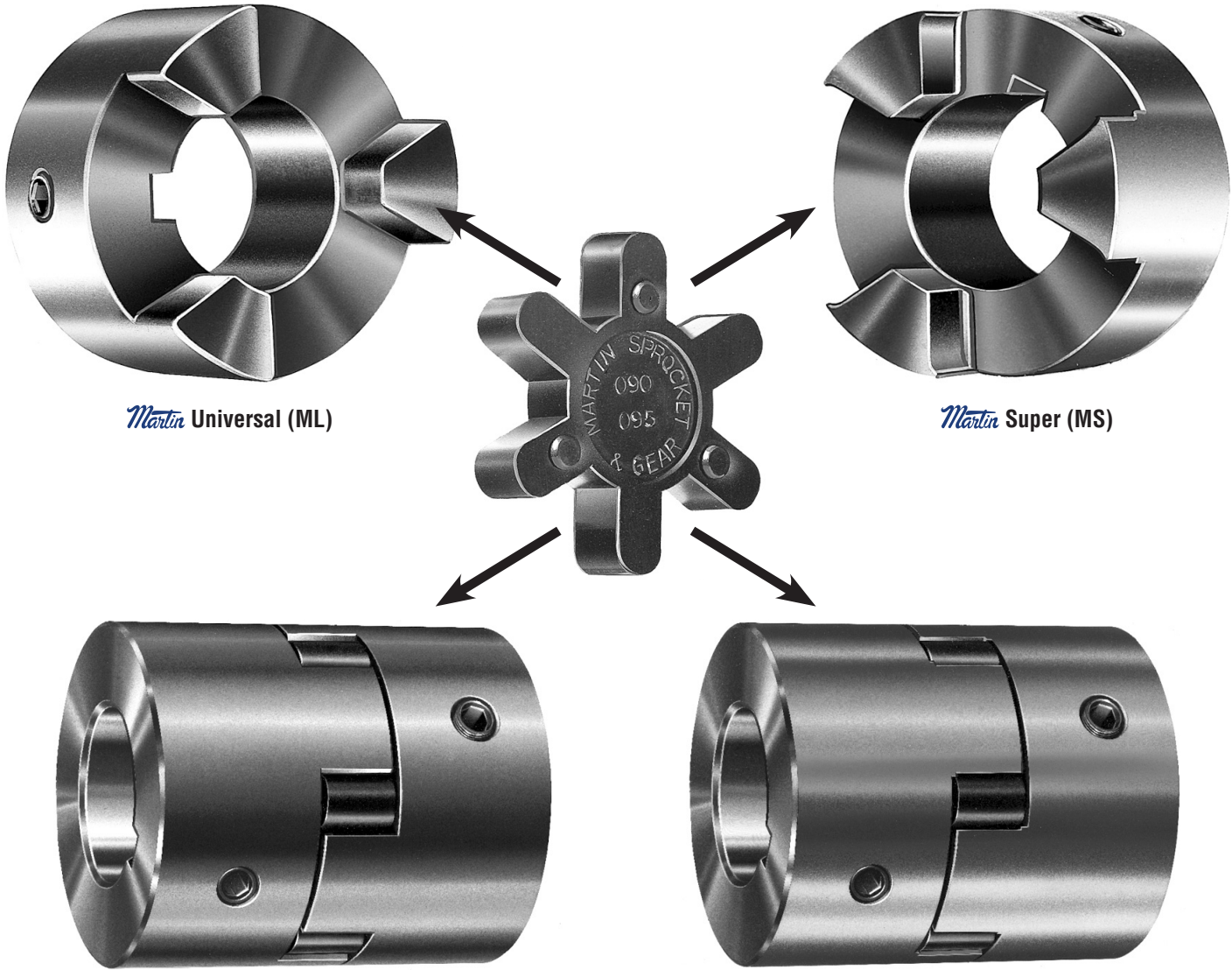

Now *Martin* Offers Two Styles

The *Martin* Super — Higher Horsepower

The *Martin* Universal — Completely Interchangeable

- No Lubrication
- Easy Installation
- No Metal to Metal Contact
- Resistant to oil, dirt, sand, moisture, grease
- Easy inspection of load carrying Spider
- Flexibility of angular or parallel misalignment of shafts by Buna-N Spider member permits smooth "Power Transmission"

Jaw Coupling Selection Procedure

- Determine Service Factor by Matching Driven Unit with Prime Mover in Service Factor Guide.
- Multiply Service Factor by Driven Unit or Motor HP to Obtain Adjusted HP.
- Select Flexible Coupling with Horsepower Capacity Equal to or Greater than Adjusted HP.

Service Factor Guide	Prime Mover		
	Electric Motor or Steam Turbine	Gasoline or Diesel Engine, 6 or More Cyl.	Gasoline or Diesel Engine, Less Than 6 Cyl.
Driven Unit (Machinery)			
Light: Uniform or steady load never exceeding horsepower rating, infrequent starting. Agitators, Blowers, Conveyors, Evaporators, Fans, Generators, Centrifugal Pumps, Stokers	1.0	1.5	2.0
Moderate: Heavy inertia, moderate shock, frequent starting; peak loads do not exceed 125 per cent average horsepower. Uneven load. Beaters, Rotary Pumps and Compressors, Cranes, Elevators, Mine and Propellor Fans, Generators, Pulp Grinders, Hoists, Kilns, Machine Tools, Mixers, Gear Pumps, Woodworking Machines	1.5	2.0	2.5
Heavy: Heavy shock conditions or frequent reversing. Peak loads do not exceed 150 per cent average horsepower. Uneven load. Reciprocating Pumps and Compressors, Crushers, Freight and Passenger Elevators, Mills (Hammer, Ball, Rolling, Turf, Flour), Vibrating Screens, Winches, Wire Drawing Machines, Punches, Shears	2.0	2.5	3.0

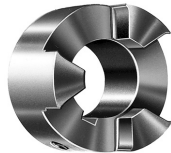
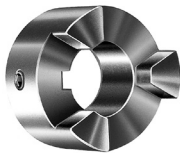

Bore Tolerances:
 0.5 – 1.75 + 0.001 – 0.000
 1.8125 – 2.625 + 0.0015 – 0.0000

Martin ML (Universal Series) — Torque and Horsepower Ratings

Catalog Number	Stainless Steel Catalog Number	Torque Rating lb — in		Buna-N Horsepower Capacity at Various RPM					Max. Bore	(Each) Weight
		Buna-N	Hytrel®	100	300	1200	1800	3600		
ML035	ML035SS	3.5	—	0.006	0.02	0.07	0.10	0.20	0.375	0.10
ML050	ML050SS	31.5	94.5	0.05	0.15	0.60	0.9	1.8	0.625	0.15
ML070	ML070SS	42	126	0.07	0.21	0.84	1.2	2.5	0.750	0.31
ML075	ML075SS	81	242	0.13	0.39	1.56	2.3	4.7	0.875	0.45
ML090	ML090SS	140	420	0.22	0.66	2.64	4.0	7.9	1.125	0.75
ML095	ML095SS	189	567	0.30	0.90	3.6	5.4	10.8	1.125	0.89
ML099	ML099SS	290	870	0.46	1.4	5.5	8.3	16.6	1.375	1.02
ML100	ML100SS	416	1248	0.66	2.0	7.9	11.9	23.8	1.375	1.48
ML110	ML110SS	756	2268	1.2	3.6	14.4	21.6	43.2	1.625	3.18
ML150	ML150SS	1197	3591	1.9	5.7	22.8	34.2	68.4	1.875	4.83
ML190	ML190SS	1512	4536	2.4	7.2	28.8	43.2	86.4	2.125	7.65
ML225	ML225SS	2268	6804	3.6	10.8	43.2	64.8	129.6	2.625	10.66

Martin MS (Super Series) — Torque and Horsepower Ratings

Catalog Number	Torque Rating lb — in		Buna-N Horsepower Capacity at Various RPM					Max. Bore	(Each) Weight
	Buna-N	Hytrel®	100	300	1200	1800	3600		
MS050	37.3	112	0.06	0.18	0.71	1.0	2.1	0.625	0.13
MS070	59.4	178	0.09	0.28	1.1	1.7	3.4	0.750	0.25
MS075	157	471	0.25	0.75	3.0	4.5	8.9	0.875	0.53
MS090	241	723	0.38	1.1	4.6	6.9	13.7	1.125	0.58
MS095	241	723	0.38	1.1	4.6	6.9	13.7	1.125	0.70
MS099	512	1536	0.81	2.4	9.7	14.6	29.2	1.325	1.12
MS100	512	1536	0.81	2.4	9.7	14.6	29.2	1.325	1.43
MS110	1014	3042	1.6	4.8	19.3	28.9	57.8	1.325	3.24
MS150	1630	4890	2.6	7.7	31.0	46.5	93.0	1.875	4.76
MS190	2450	7350	3.9	11.6	46.6	69.9	139.7	2.125	7.66
MS225	2920	8760	4.6	13.9	55.5	83.2	166.5	2.625	10.76

NOTE: Above HP capacities are for Buna-N rubber spider and service factor of one. When Hytrel spider is used multiply capacities by three.
Misalignment Capacities: Angular up to 1°, Parallel up to .015 inches.
 Hytrel is a registered trademark of E.I. DuPont & Co.

Stock Jaw Couplings

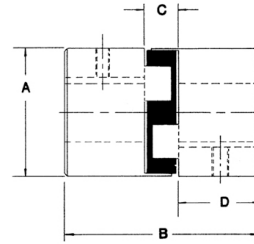
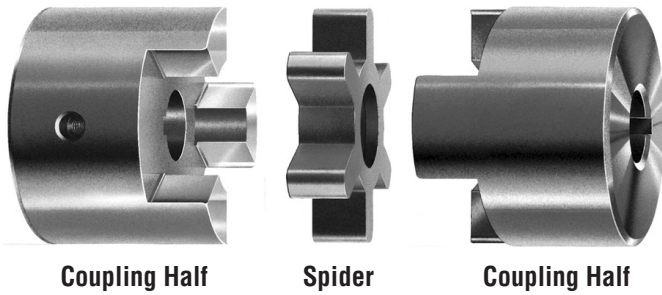

Dimensions

Catalog Number	Hub Dia.		Overall Length	Distance Between Flanges	Length Thru Bore	Bore		Weight (lb)
	A	B				Min.	Max.	
ML035	.625	.813	.281	.266	.125	.375	.07	
ML or MS050	1.167	1.719	.469	.625	.25	.625	.13	
ML or MS070	1.375	2	.5	.75	.25	.75	.25	
ML or MS075	1.75	2.125	.5	.813	.25	.875	.44	
ML or MS090	2.125	2.125	.5	.813	.25	1.125	.69	
ML or MS095	2.125	2.5	.5	1	.438	1.125	.84	
ML or MS099	2.531	2.875	.75	1.167	.5	1.375	1.19	
ML or MS100	2.531	3.5	.75	1.375	.5	1.375	1.47	
ML or MS110	3.313	4.25	.875	1.688	.5	1.625	3.20	
ML or MS150	3.75	4.5	1	1.75	.625	1.875	4.50	
ML or MS190	4.5	4.875	1	1.938	.75	2.125	8.25	
ML or MS225	5	5.375	1	2.188	.75	2.625	12.00	

Bore sizes are standard in .167" increments from minimum to maximum bore range and have keyway and set screw except as shown below:

- .125 through .375 Bore — No KW — No SS
- #050 — .438 through .625 Bore — No KW — 1-SS
- #070, 075, 090, 095 — .438 and .5 Bore — No KW — 1-SS
- #099, 100, 110 — .5 Bore — No KW — No SS
- #150 — .625 Bore — No KW — No SS
- #190, 225 — .75 Bore — No KW — No SS

NOTE: In each coupling size a min. plain bore is available that can be used to make special bores such as spline, hex, metric, or other shapes or sizes.

For Standard Keyway sizes see *Martin* Catalog, page E-158 and E-159.

Coupling Selection Chart for 60 Hz Nema Motor Frames Based on Buna-N (Rubber) Spider ★†

Shaft Dia.	Nema Frame	Coupling Size	Max. HP @ RPM					
			1140		1725		3450	
			MS	ML	MS	ML	MS	ML
.375	42	050	.5	.5	1	.75	2	1.5
.5	48	050	.5	.5	1	.75	2	1.5
.625	56,56 H	050	.5	.5	1	.75	2	1.5
.75	66	070	1	.75	1.5	1	3	2
.875	56HZ, 143T, 145T	075	2	1	3	2	7.5	3
	182, 184	090	3	2	5	3	10	7.5
1.125	182T, 184T, 213	095	3	3	5	5	10	10
	215	099	7.5	5	10	7.5	25	15
1.375	213T, 215T, 245U, 256U	100	7.5	7.5	10	10	25	20
1.625	254T, 256T, 248U, 286U	110	15	10	25	20	50	40
1.875	284T, 286T, 324U, 326U, 326TS	150	30	20	40	30	75	60
2.125	324T, 326T, 364U, 365U	190	40	25	60	40	125	75
2.375	364T, 365T	225	50	40	75	60	150	100

NOTE: Coupling Sizes are based on the rated torque, max. bore and a have a service factor of 1.0.

★ When using Hytrel or Bronze spider multiply above horsepower ratings by 3.

† When using Urethane spider multiply above horsepower ratings by 1.5.

Spiders – Buna-N (Rubber) and Hytrel

Catalog Number		Accommodates Coupling	Net Weight lb	
Buna-N	Hytrel		Buna-N	Hytrel
SRL035	SHL035	ML035	.009	.009
SRL050	SHL050	M 050 — MS 050	.013	.013
SRL070	SHL070	ML070 — MS 070	.017	.017
SRL075	SHL075	ML075 — MS 075	.03	.03
SRL090	SHL090	ML or MS090-095	.04	.04
SRL099	SHL099	ML or MS099-100	.07	.07
SRL110	SHL110	ML110 — MS110	.14	.14
SRL150	SHL150	M150 — MS150	.21	.21
SRL190	SHL190	ML190 — MS190	.27	.27
SRL225	SHL225	ML225 — MS225	.41	.41

Urethane spiders available. Please consult factory.

Spiders – Urethane† and Bronze ★

Catalog Number		Accommodates Coupling	Net Weight lb	
Buna-N	Hytrel		Buna-N	Hytrel
SUL035	SBL035	ML 035	.009	0.05
SUL050	SBL050	ML050 — MS050	.013	0.08
SUL070	SBL070	ML070 — MS070	.017	0.06
SUL075	SBL075	ML075 — MS075	.03	0.15
SUL090/ 095	SBL090/ 095	ML or MS 090-095	.04	0.17
SUL 099/ 100	SBL099/ 100	ML or MS 099-100	.07	0.50
SUL110	SBL110	ML110 — MS110	.14	0.62
SUL150	SBL150	ML150 — MS150	.21	1.00
SUL190	SBL190	ML190 — MS190	.27	1.30
SUL225	SBL225	ML225 — MS225	.41	1.60

★ Bronze spiders available as Made-to-Order.



Metric Bore Sizes Available
Consult Factory