



川源（中国）机械有限公司
GSD Industrial Co.,Ltd.



GreatOrientalTrading
www.gotrading.co.th

@gotrading

GreatOrientalTrading

097-3619703



MA/LFP

潜水搅拌机

MA/LFP submersible mixer

MA/LFP 潜水搅拌机

MA/LFP submersible mixer



低速推流器
Low-speed flow propeller



混合搅拌机 (带导流罩)
Mixing agitator (With dome)



混合搅拌机
Mixing agitator

特点 Features

- 两道独立的机械密封，保证潜水电机长期可靠运行。
- 高质量国际知名品牌免维护轴承，使用寿命长。
- 独特的电缆密封设计，排除了电缆漏水的隐患。
- 电机轴采用不锈钢材质，转子经动平衡检测，运转平稳。
- 内部设有泄漏传感器和定子绕组超温保护装置（MA0.37/6、MA0.55/4无泄漏传感器）。
- 混合搅拌器的不锈钢冲压叶浆，经优化设计叶片呈后掠式，效率高，具有自清洁功能。
- 低速推流器叶浆由玻璃钢制成，呈后掠式，具有自清洁功能；叶浆光滑的流线型表面，使推力被平均分配。
- 低速推流器所有接触介质的紧固件均采用不锈钢材质；减速装置采用安全系数较高的斜齿轮减速机。

用途 Purpose

GSD潜水搅拌机分为混合搅拌机与低速推流器，主要适用于：市政和工业污水处理过程中的混合、搅拌和环流：活性污泥池、生物反应池、搅拌池、贮泥井、均衡池、污水池等；景观水环境的养护设备，改善水体质量；创建水流，有效阻止悬浮物沉积。

The submersible mixers in our company include mixing agitator and low-speed flow propeller, mainly used for: The purposes of mixing, agitating and making ring flows in the process of municipal and industrial sewage treatment: activated sludge tank, bioreactor tank, mixing tank, sludge silos, equalizing reservoir, sewage tank and etc.; The maintenance equipment for the landscape water environment, improving the quality of the water body; Creating water flow, effectively preventing the sedimentation of the suspended substances.

- The two rows of independent mechanical sealing ensure the long-term and reliable operation of the submersible motor.
- The international well-known high-quality bearings have longer service life, which are maintenance free.
- The unique sealing design for the cables removes the hidden danger of water leakage for the cables.
- The shaft of the motor employs the stainless steel, and the rotors are inspected with the use of dynamic balancing, leading to smooth rotation.
- The in-built leakage sensor and the device for the overtemperature protection for the windings of the stator(No leakage sensor for MA0.37/6 or MA0.55/4).
- The mixer agitators have the stainless steel pressing impeller, which are of the sweptback shape through the optimized design, resulted in high efficiency and self-cleaning function.
- The vanes of the low-speed flow propeller are made of FRP, which are sweptback shape, have the self-cleaning function, the smooth and streamlined propeller surface distributes the propelling power equally.
- On the low-speed flow propeller, all the tightening pieces which will contact media employ the stainless-steel material; The decelerator employs helical gear speed reducer with high safety coefficient.



适用条件

- 介质温度：≤40℃
- 介质pH值：5~9
- 介质密度：≤1150kg/m³
- 潜水深度：≤20m
- 电源：380V，50Hz
- 电机：F级绝缘并符合IP68，24小时连续运行
- 潜水搅拌机必须完全潜入水中工作

Conditions of usage

- The highest temperature of the media shall not exceed 40℃
- The pH value of the media: 5~9
- The density of the media shall not exceed 1150kg/m³
- The depth of submersion shall not exceed 20m
- The electric power supply: 380V, 50Hz
- The motor: F class insulation and in accordance with IP68, continuous operating in 24hr
- The submersible mixer must operate in the complete submersion into water

结构简图 Construction

不同功率结构略有不同

The structure will be different according to the power.

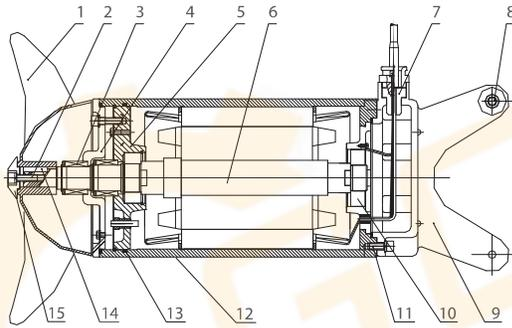

NO.	名称	Name	材质	
			GB	JIS
1	叶桨	Propeller	0Cr19Ni10	SUS304
2	锁紧螺钉	Lock nut	0Cr19Ni10	SUS304
3	机械密封	Mechanical seal	SiC-SiC	SiC-SiC
4	机封座	Mechanical seal stand	0Cr19Ni10	SUS304
5	前轴承座	Front bearing support	HT200	FC200
6	主轴	Main shaft	2Cr13	SUS420J1
7	水密头	Watertight head	硫化橡胶	VR
8	滚轮	Roller	0Cr19Ni10	SUS304
9	接线盒	Junction box	0Cr19Ni10	SUS304
10	轴承	Bearing	-	-
11	内六角螺钉	Inner hexagonal screw	0Cr19Ni10	SUS304
12	机壳	Sheath	0Cr19Ni10	SUS304
13	O型橡胶密封圈	O-type sealant ring	丁腈-70/NBR-70	NBR-70
14	平键	Flat key	45	S45C
15	叶轮压紧圈	Wheel clamp ring	0Cr19Ni10	SUS304

上表为MA标配材质，其它材质请另询！

The table above is standard material for MA type. If other material needed, pls contact us.

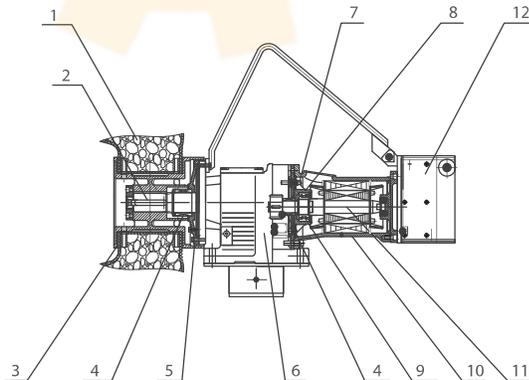

NO.	名称	Name	材质	
			GB	JIS
1	叶桨	Propeller	玻璃钢	FRP
2	输出轴	Output shaft	2Cr13	SUS420J1
3	轮毂	Wheel boss	HT200	FC200
4	机械密封	Mechanical seal	SiC-SiC	SiC-SiC
5	机封座	Mechanical seal stand	HT200	FC200
6	减速机	Decelerator	HT200	FC200
7	泄漏传感器	Leakage sensor	-	-
8	轴承座	Bearing stand	HT200	FC200
9	轴承	Bearing	-	-
10	机壳	Sheath	HT200	FC200
11	电机轴	Motor shaft	2Cr13	SUS420J1
12	滑套	Slide sleeve	HT200	FC200

上表为LFP标配材质，其它材质请另询！

The table above is standard material for LFP type. If other material needed, pls contact us.

型号说明 Type description



性能参数 Performance parameters

混合搅拌器 Mixing agitator

泵型号 Pump model	电机功率 Motor power (kW)	额定电流 Rated current (A)	叶桨转速 rpm of propeller (r/min)	叶桨直径 Diameter of propeller (mm)	推力 Thrust (N)	重量 Weight (kg)
MA0.37/6-220-960	0.37	1.3	960	220	138	45/50
MA0.55/4-220-1400	0.55	1.6	1400	220	145	45/50
MA0.85/8-260-740	0.85	3.2	740	260	163	55/65
MA1.5/6-260-960	1.5	4	960	260	290	55/65
MA2.2/8-320-740	2.2	5.9	740	320	582	88/93
MA4/6-320-960	4	10.3	960	320	609	88/93
MA1.5/8-400-740	1.5	5.2	740	400	600	74/82
MA2.5/8-400-740	2.5	7	740	400	800	74/82
MA3/8-400-740	3	8.6	740	400	920	74/82
MA4/6-400-960	4	10.3	960	400	1200	74/82
MA4/12-620-480	4	14	480	620	1400	190/206
MA5/12-620-480	5	18.2	480	620	1800	196/212
MA7.5/12-620-480	7.5	28	480	620	2600	240/256
MA10/12-620-480	10	32	480	620	3300	250/266

注：1、上表“重量”一栏分别表示不带流罩和含流罩的重量。
In the above table, the value listed in the column of "weight" respectively contains the weight of without or with the dome.
2、叶桨直径220mm的混合搅拌器叶桨为二叶片式，其余均为三叶片式。
Mixer agitator whose propeller diameter is 220mm has two vanes, other has three vanes.

低速推流器 Low-speed flow propeller

泵型号 Pump model	电机功率 Motor power (kW)	额定电流 Rated current (A)	叶桨转速 rpm of propeller (r/min)	叶桨直径 Diameter of propeller (mm)	推力 Thrust (N)	重量 Weight (kg)
LFP2.2/4-1100-52	2.2	4.9	52	1100	1100	172
LFP3/4-1100-63	3	6.8	63	1100	1500	175
LFP4/4-1100-85	4	8.8	85	1100	2600	212
LFP3/4-1400-43	3	6.8	43	1400	1740	183
LFP4/4-1400-52	4	8.8	52	1400	2950	186
LFP3/4-1800-34	3	6.8	34	1800	2320	210
LFP4/4-1800-43	4	8.8	43	1800	3200	212
LFP3/4-2500-34	3	6.8	34	2500	2500	220
LFP4/4-2500-43	4	9.3	43	2500	3080	230
LFP7.5/4-2500-52	7.5	15.5	52	2500	3940	319

注：上述低速推流器叶桨为二叶片式，如需三叶片式，请另询。
The low-speed flow propeller above has two vanes, If three vanes needed, pls contact us.



流场图 Diagrams of the flow field

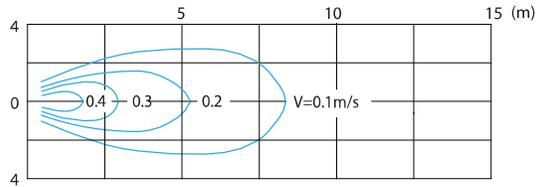

MA0.37/6-220-960

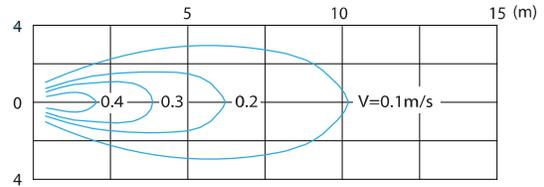

MA0.55/4-220-1400

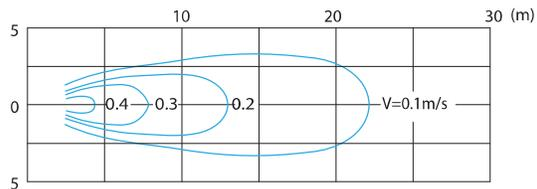

MA0.85/8-260-740

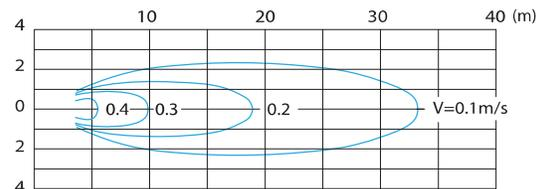

MA1.5/6-260-960

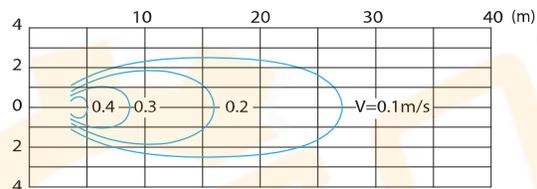

MA1.5/8-400-740

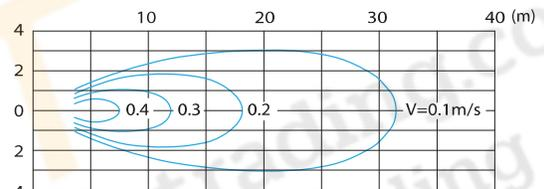

MA2.2/8-320-740

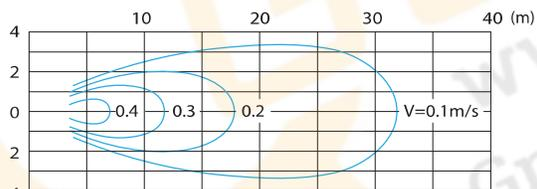

MA2.5/8-400-740

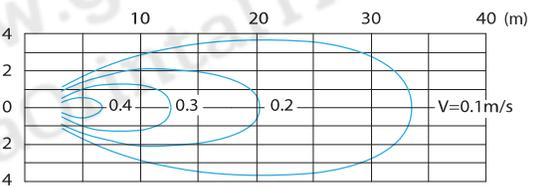

MA3/8-400-740

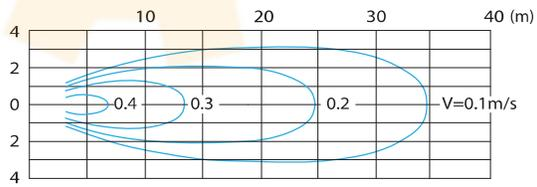

MA4/6-320-960

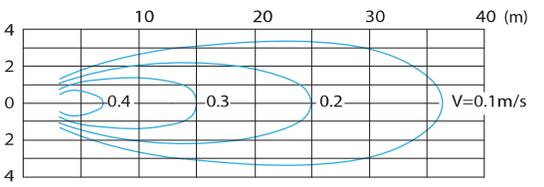

MA4/6-400-960

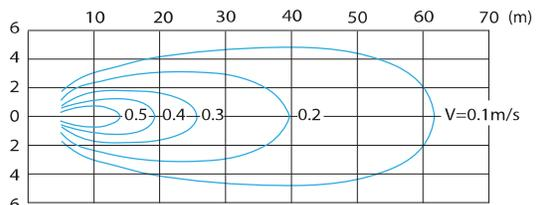

MA4/12-620-480

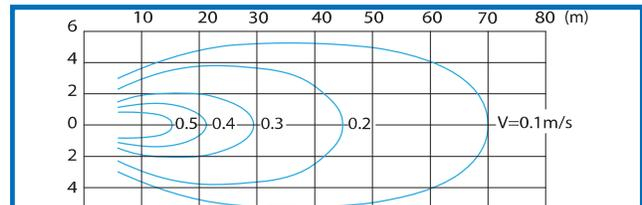

MA5/12-620-480

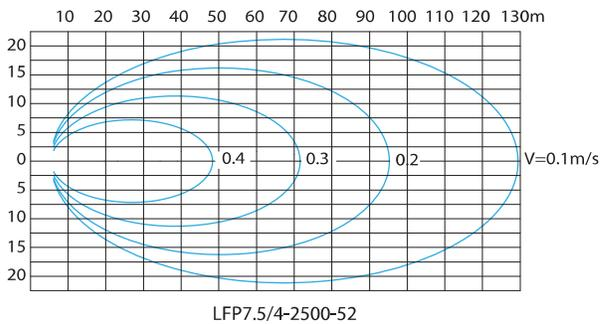
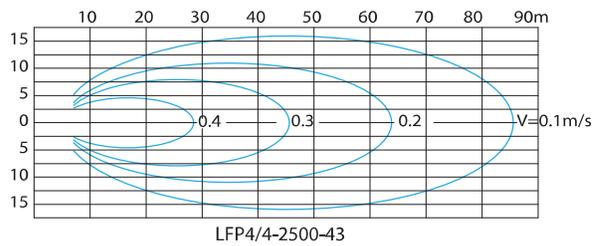
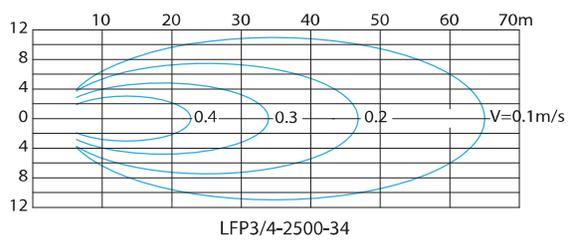
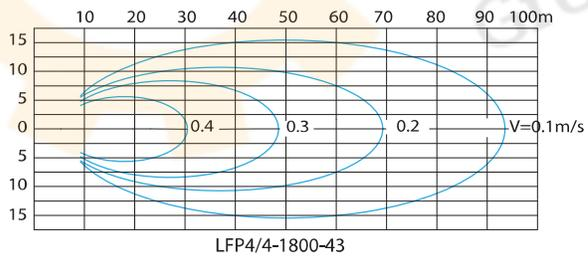
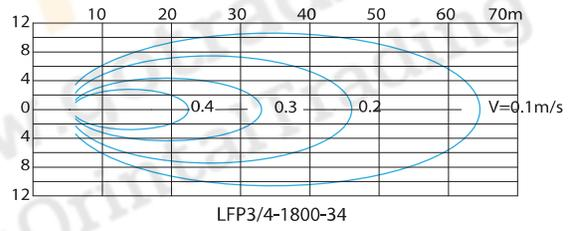
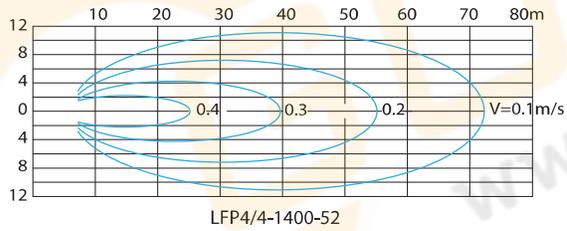
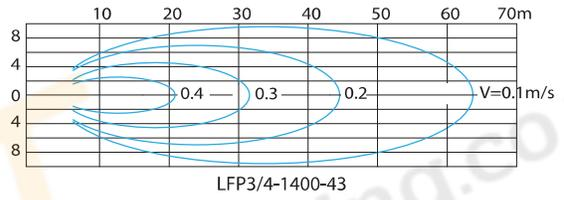
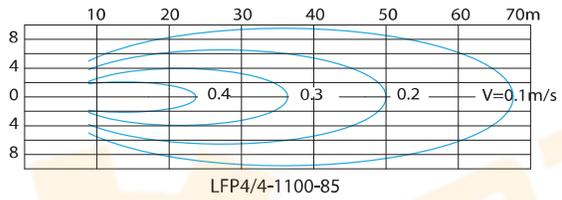
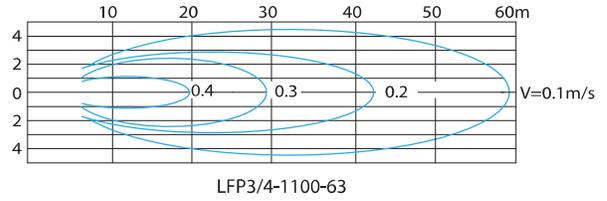
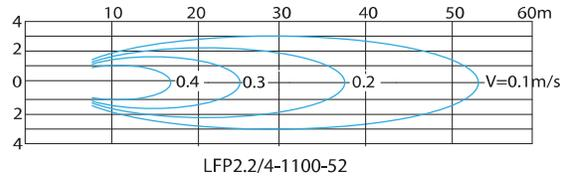
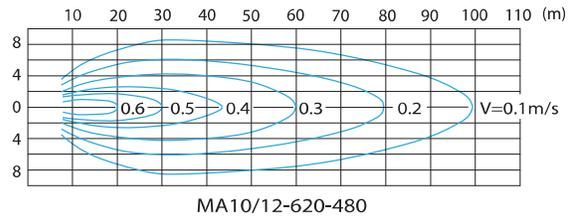
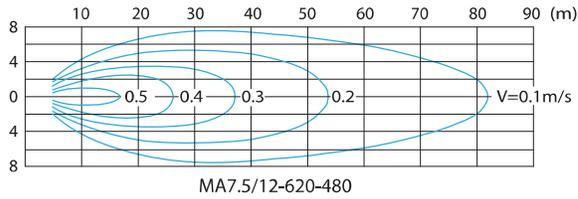

安装方式及尺寸

潜水搅拌机可以有多种安装方式，这里提供最通用的方式供选择，尺寸可参考下表。我公司还可以根据用户的要求作特殊设计。

型号 Type	a	D	b	L	H _{1min}	H _{2min}	安装系统 Installation system
MA0.37/6-220-960	∅40/□50	340	330/235	520/960	500/800	110/150	I/II
MA0.55/4-220-1400	∅40/□50	340	330/235	520/960	500/800	110/150	I/II
MA0.85/8-260-740	∅48/□50	360	330/235	630/960	500/800	110/150	I/II
MA1.5/6-260-960	∅48/□50	360	330/235	630/960	500/800	110/150	I/II
MA2.2/8-320-740	□70	460	320	970	800	150	II
MA4/6-320-960	□70	460	320	970	800	150	II
MA1.5/8-400-740	□70	500	320	960	800	200	II
MA2.5/8-400-740	□70	500	320	960	800	200	II
MA3/8-400-740	□70	500	320	1010	800	200	II
MA4/6-400-960	□70	500	320	1010	800	300	II
MA4/12-620-480	□100	760	335	1150	1100	300	III
MA5/12-620-480	□100	760	335	1150	1100	300	III
MA7.5/12-620-480	□100	760	335	1280	1500	300	III
MA10/12-620-480	□100	760	335	1280	1500	300	III
LFP2.2/4-1100-52	□100	1100	210	1300	1000	270	IV
LFP3/4-1100-63	□100	1100	210	1300	1000	270	IV
LFP4/4-1100-85	□100	1100	210	1350	1000	270	IV
LFP3/4-1400-43	□100	1400	210	1350	800	125	IV
LFP4/4-1400-52	□100	1400	210	1400	800	125	IV
LFP3/4-1800-34	□100/∅89	1800	210/600	1350/1400	800	125	IV/V
LFP4/4-1800-43	□100/∅89	1800	210/600	1400/1400	800	125	IV/V
LFP3/4-2500-34	□100/∅89	2500	210/600	1350/1450	1000	125	IV/V
LFP4/4-2500-43	□100/∅89	2500	210/600	1400/1450	1000	125	IV/V
LFP7.5/4-2500-52	□100/∅102	2500	200/600	1450/1450	1000	125	VI/VII

注：

- 潜水搅拌机的专用安装系统，可在无需排出池中污水的情况下，快速安装和拆卸潜水搅拌机。
- 安装系统 I 只适用 H ≤ 3m，机型为 MA0.37/6、MA0.55/4、MA0.85/8 和 MA1.5/6，可在水平方向和垂直方向调节角度。
- 安装系统 II、III 导杆可沿水平方向绕导杆轴线旋转，最大转角为 ±60°，当 H > 4m 时需在导杆中间添加一支撑架。
- 支撑架和下托架与池壁、池底均可用膨胀螺栓或化学锚栓固定，对于大直径叶轮和大功率搅拌机最好采用预埋。
- 客户订货时，请提供池深 H 及池型图，以便确定导杆尺寸和支撑架个数。
- 同一种安装系统，多台搅拌机可共用一套起吊系统。
- 安装系统可选择采用不锈钢或碳钢防腐材质。
- LFP 叶桨直径为 1100mm 时，安装系统无斜撑。

Installation modes and dimensions

The submersible mixers can be installed in a multiple of modes. Here are generally accepted modes of installation for selection with reference made to the following table. Our company can also provide the special designs in accordance with the demand of the users.

Notes:

- The special installation systems for the submersible mixers can facilitate the quick installation and dismantling of the submersible mixers under the conditions of no need for draining off sewage from the pond.
- Installation System I is only suitable for H ≤ 3m and the mixer models of MA0.37/6, MA0.55/4, MA0.85/8 and MA1.5/6, and with the possibility of adjusting the angles in both horizontal direction and longitudinal direction.
- For installation systems II and III, the guide rod can rotate round the axial line of the guide rod along the horizontal direction with the maximum angle of rotation ±60°, if H > 4m, it is necessary to add a supporting frame between the guide rods.
- The supporting frame and the lower support shall be fixed onto the pond wall and the pond bottom with the use of expansion bolts or chemical anchors. For the big diameter impellers and the big power mixers the best choice is to pre-embed.
- While placing an order by customer. Please supply the pond depth H and the drawing of the pond shape so as to determine the dimensions of the guide rod and the number of the supporting frames.
- A multiple of mixers with the same installation system can share one lifting system.
- The installation systems may employ the material of stainless steel or carbon steel for the selection of the corrosion-resisting properties.
- The LFP installation system has not the slant support, when the impeller diameter is 1100mm.

外形及安装尺寸 Installation dimensions

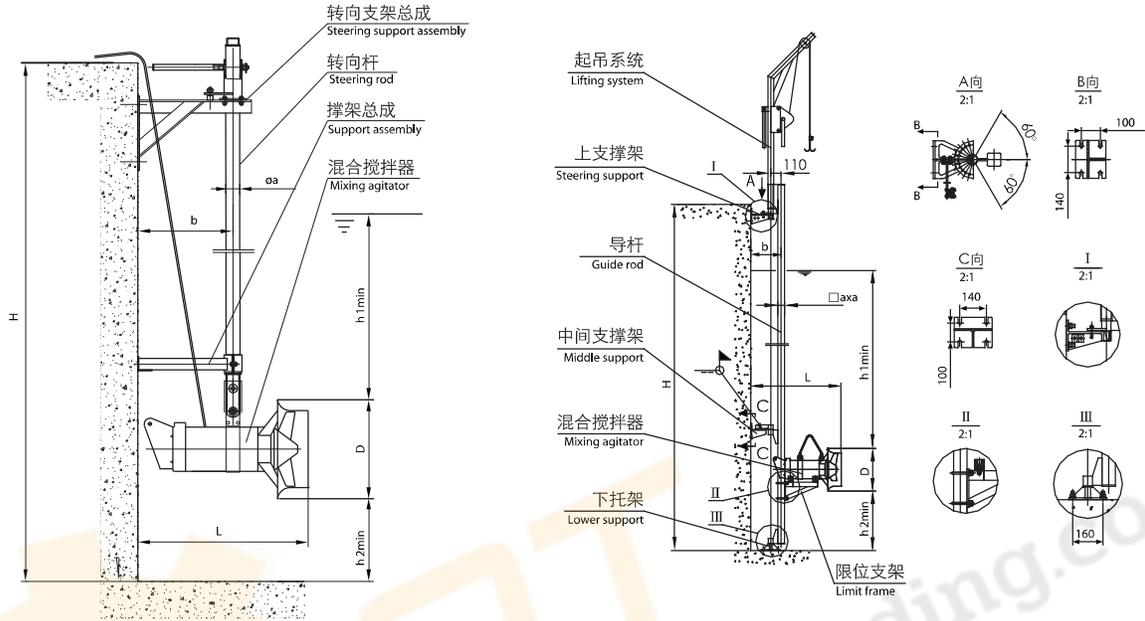

System I

System II

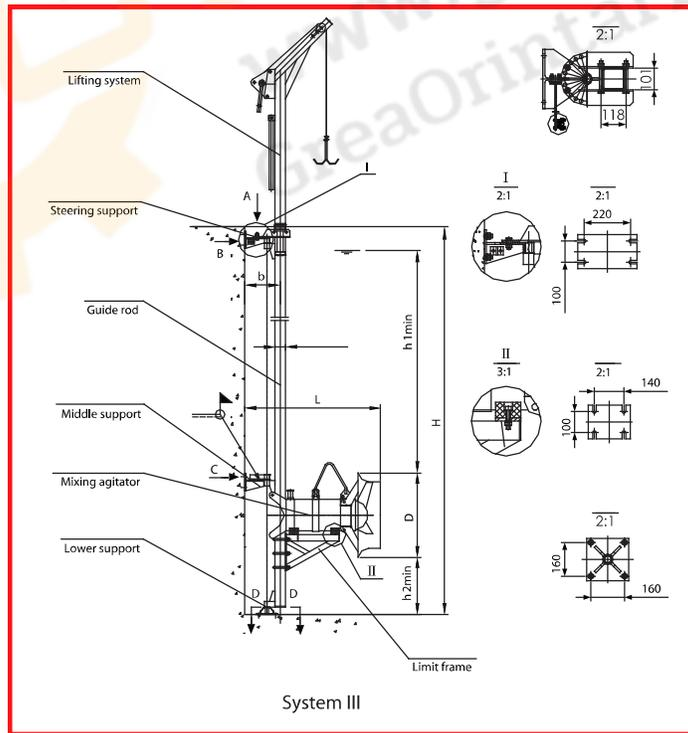

System III



外形及安装尺寸 Installation dimensions

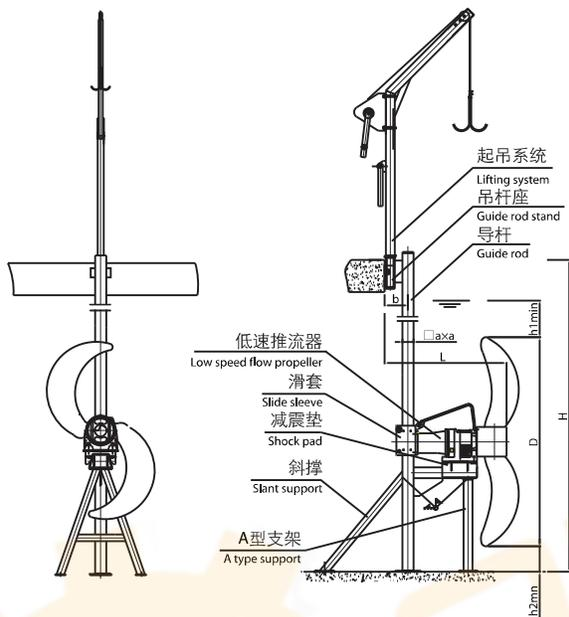

System IV

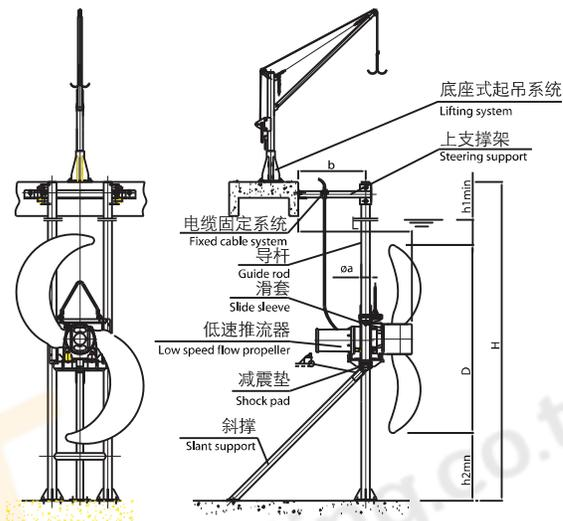

System V

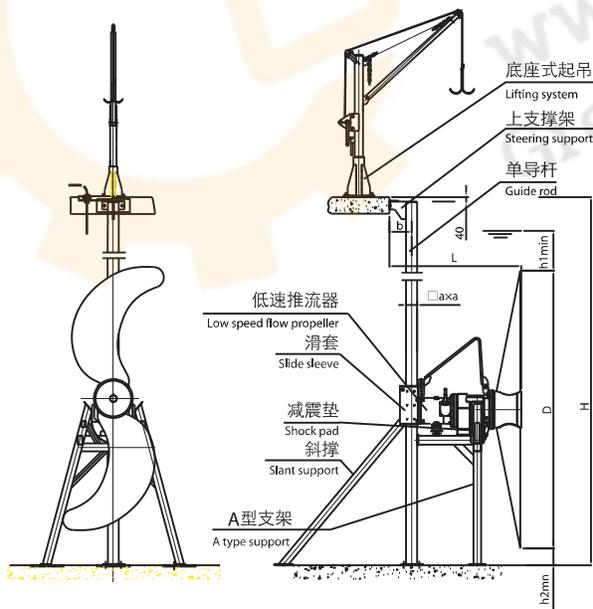

System VI

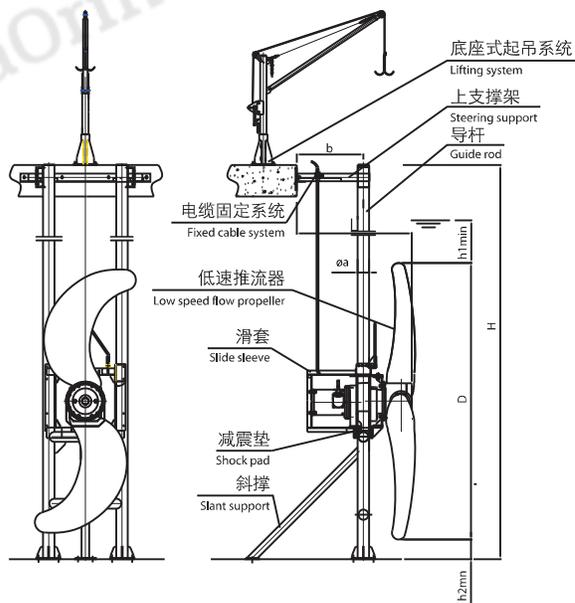

System VII



配置示意图

潜水搅拌机的安装定位对其搅拌效果有很大的影响，为了达到良好的运行效果，我们建议用户按照专业设计人员的要求去做，要充分考虑到水池的形状，进出水的位置以及搅拌机的水流反射到构筑物而引起的涡流等情况，尽量减少短路循环和死角产生，避免与池壁的撞击而降低流速。参照下面的配置示意图，可帮助您合理选择搅拌机和安装型式。

Arranging sketch map

The installation and positioning of the submersible mixers will produce a great impact on the effect of mixing. In order to obtain the perfect operating result, it is suggested that the advice of the specialized designers shall be followed and full consideration given to the shape of the pond, position of the water inlet and outlet, the vortex resulting from the outflow from the mixer onto the structures and some other conditions. Every effort shall be made to reduce the short-circuit circulation and the occurrence of dead corners and avoid the dashing of the flow against the pond wall to lower the flow velocity. Making reference to the arranging sketch map below will help you to make a reasonable selection of the mixers and their installation modes.

混合搅拌器 Mixing agitator

避免短路循环
Avoid short circuit flows

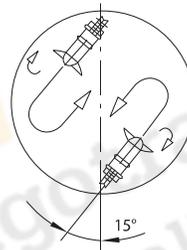
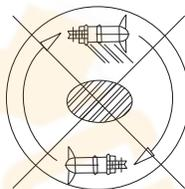

考虑进出口
Take inlet and outlet into account

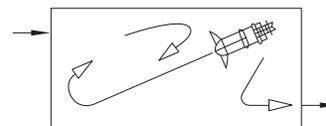
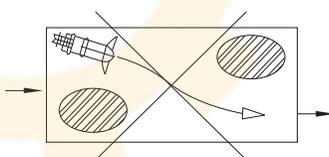

考虑喷射流范围，避免与池壁发生不必要的冲撞
Take jet expansion into account, no unnecessary wall friction.

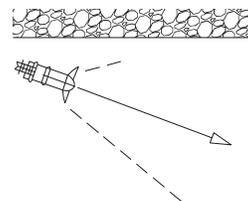
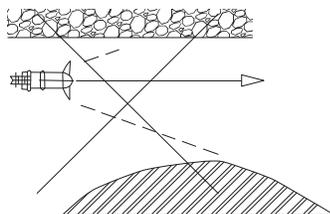

安装引起的死区
Installations cause dead zones

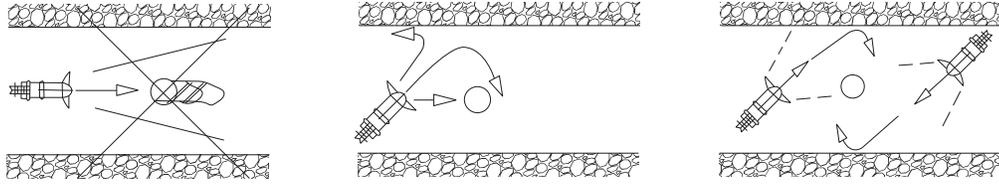

喷射流的交叉
Jet intersections

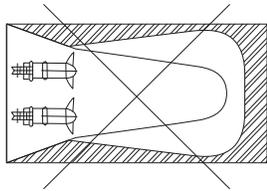

考虑到恒一能量的供应
Take uniform energy supply into account

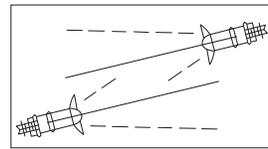

利用池壁反射
Use wall reflections

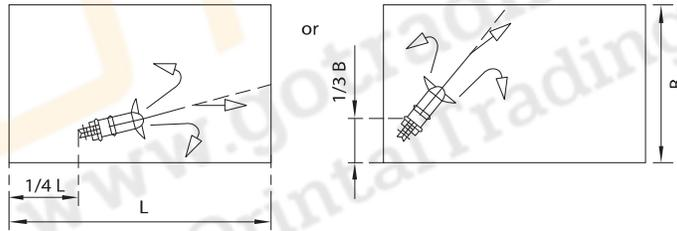
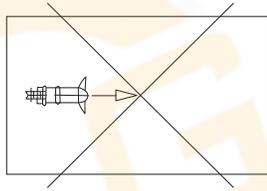

低速推流器 Low-speed flow propeller

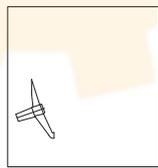

方形池 Square pond

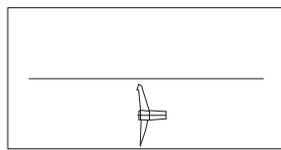

矩形池 Rectangular pond

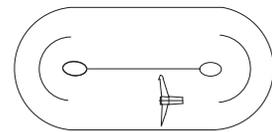

跑道形池 Track-shaped pond

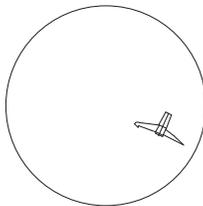

圆形池 Circular pond

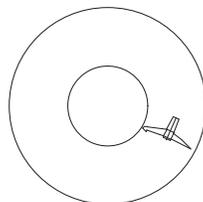

环形池 Ring-shaped pond

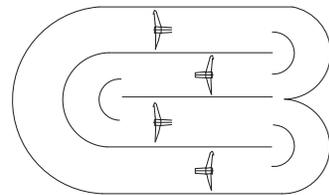

S曲线形池 S-shaped pond

如蒙洽询请指示下列各项
For further details, please fulfill the chart below.

客户 Customer _____ 承办人员 Undertaker _____
 工程名称 Name of project _____ 工程地点 Address of project _____
 电话 Telephone _____ 传真 Fax _____

基本选型参数 Basic parameters	* 工艺名称 Processes name	氧化沟 Oxidation ditch <input type="checkbox"/>	A-O法 A-O <input type="checkbox"/>	SBR法 SBR <input type="checkbox"/>	其它(注) Others					
	* 安装位置 Installation location	其它(注) Others								
	* 基本池型(m) Pond form	长 L	宽 W	深 H	长 L	宽 W	深 H	长 L	宽 W	深 H
	* 有效水深(m) Available water depth									
介质参数 Media parameter	介质名称 Name				密度 Density					
	主要成分 Main composition				* PH 值 PH					
	* 温度 Temperature				黏度 Viscosity					
	其它 Other									
工艺要求参数 Technique parameters	* 主要搅拌混合方式 Mixing methods	搅拌型 Mixing agitator <input type="checkbox"/>		推流型 Flow propeller <input type="checkbox"/>		其它(注) Other				
	* 池底最低流速(m/s) Minimum flow speed at the bottom									
	其它工艺要求 Other requests									
池形结构 Pool structure	* 池沿结构 Pool surface structure	 <input type="checkbox"/>	 <input type="checkbox"/>	 <input type="checkbox"/>	其它 Others <input type="checkbox"/>					
	* 池底结构 Pool bottom structure	 <input type="checkbox"/>	 <input type="checkbox"/>	 <input type="checkbox"/>	其它 Others <input type="checkbox"/>					
材质要求 Material requests	主机壳体 Shell body				* 水下导杆及支座 Guide and support					
	搅拌叶浆 Mixing propeller				* 水上吊架及支座 Hanger and support					
	导流罩(是否需要) Fairwater(need or not)				* 螺栓、螺母及垫圈 Bolt, nut and gasket					
	主轴 Main shaft				* 提升钢丝绳 Boom hoist cable					
搅拌机结构性能参数 The machine parameters	传动方式 Driving method				电机功率(kW) Motor power					
	密封形式 Seal type				额定电流(A) Rated current					
	叶轮直径(mm) Propeller diameter				电源 Power					
	叶轮转速(rpm) Propeller speed				防护等级 Protection grade					
	推力(N) Thrust				工作制式 Working standard					
其它要求 Others										

注: 为准确选型, 项目前加注“*”号者, 请务必详加填写。 Note: In order to choose the right type, the item with “*” should be filled as detail as possible.

本型录内容如有变更, 恕不另行通知。 We reserve the right to change content without notice.

CY-E3